

# Benee's Full Skirt

## HARDWARE / TOOLS

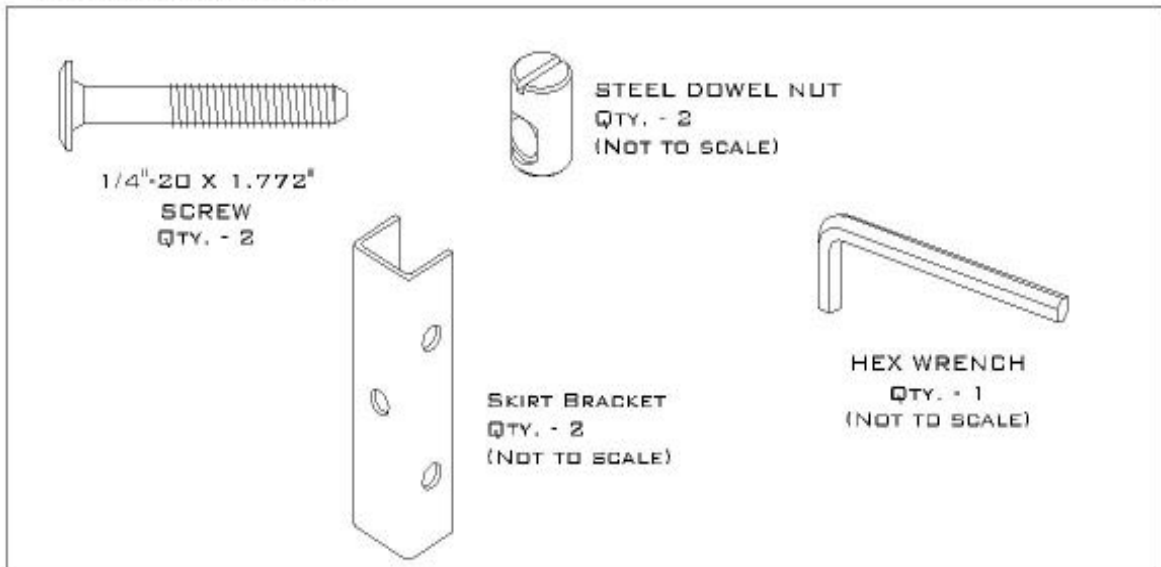

TOOL REQUIRED: PHILLIPS SCREWDRIVER, HEX WRENCH (PROVIDED), WRENCH SET.

NOTE: DO NOT USE A POWER SCREWDRIVER OR A POWER DRILL TO TIGHTEN SCREWS

INSPECT ALL PARTS FOR FREIGHT DAMAGE. IF DAMAGE IS DISCOVERED, AND IT WAS NOT NOTED ON THE BILL OF LADING AT THE TIME OF DELIVERY, PLEASE CALL **Benee's** AT 1-800-854-1411.

## PIECES ENCLOSED: (NOT SHOWN TO SCALE)

Full Skirt, qty. 1

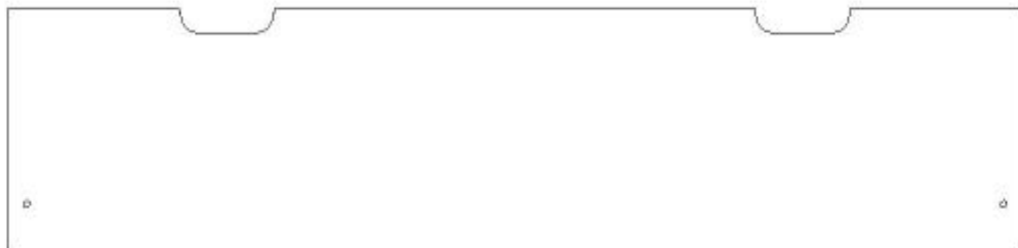

WEB SITE: BENEES.COM / EMAIL: INFO@BENEES.COM - PHONE: 1-800-854-1411  
1602 AIRPARK DRIVE - FARMINGTON, MISSOURI 65640 - FAX: (573) 756-2564  
PART# INCMD0586 - REVISION DATE: 09/10/06

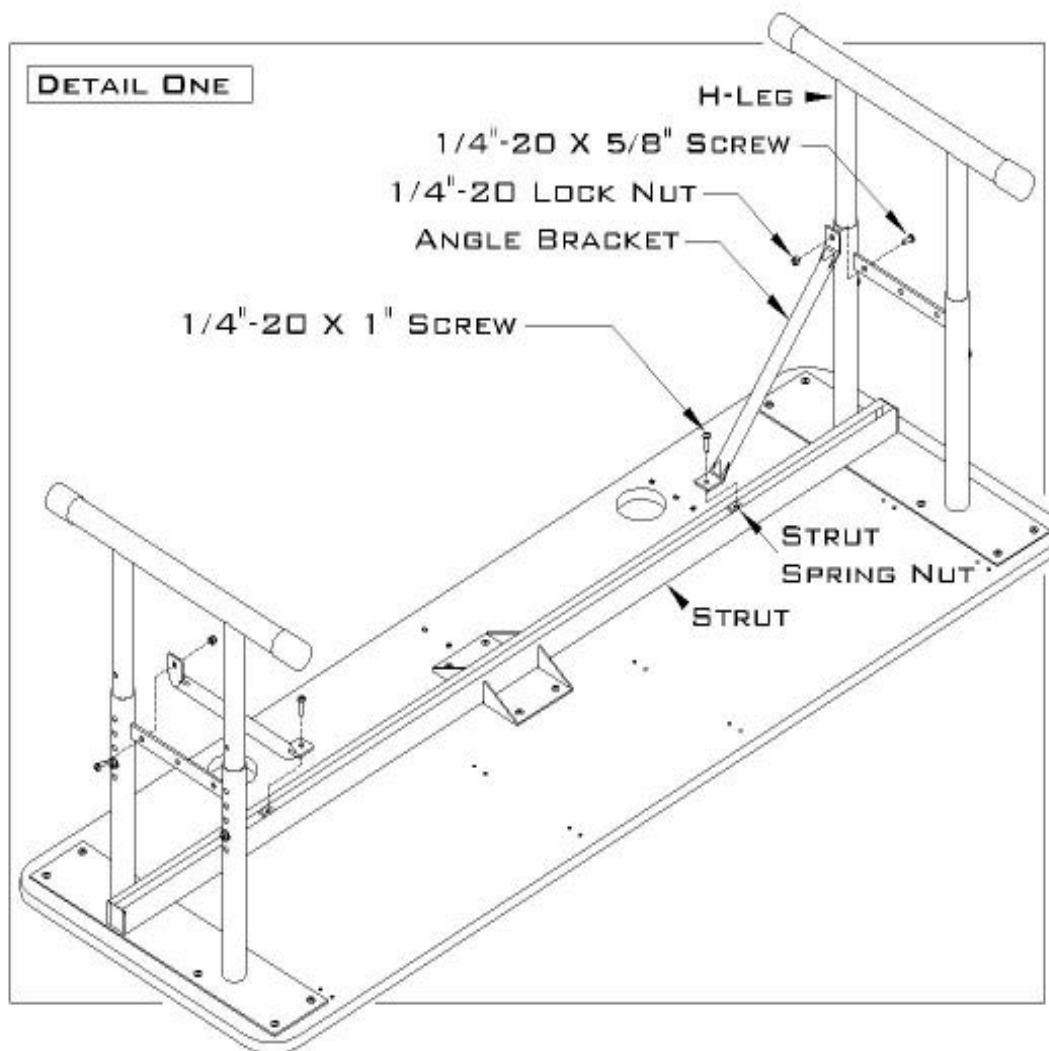

**STEP #1 - PLACE THE STRUT TABLE TOP ON THE FLOOR. REMOVE ANGLE BRACKETS AND STRUT SPRING NUTS IF THEY ARE INSTALLED. (SEE DETAIL ONE)**



WEB SITE: BEVEES.COM / EMAIL: INFO@BEVEES.COM - PHONE: 1-800-954-1611  
 1602 AIRPARK DRIVE - FARMINGTON, MISSOURI 65640 - FAX: (573) 756-2564  
 PART# INCMD0586 - REVISION DATE: 09/10/04

**STEP #2 - LOCATE FULL SKIRT (#1)  
 (2) STEEL DOWEL NUTS, AND (2) SKIRT  
 BRACKETS. INSERT STEEL DOWEL NUTS INTO  
 10.5 MM HOLES IN FULL SKIRT  
 (SEE INSET DETAIL TWO)  
 SLIDE SKIRT BRACKET OVER FINISHED  
 EDGES OF SKIRT. (SEE DETAIL TWO).**

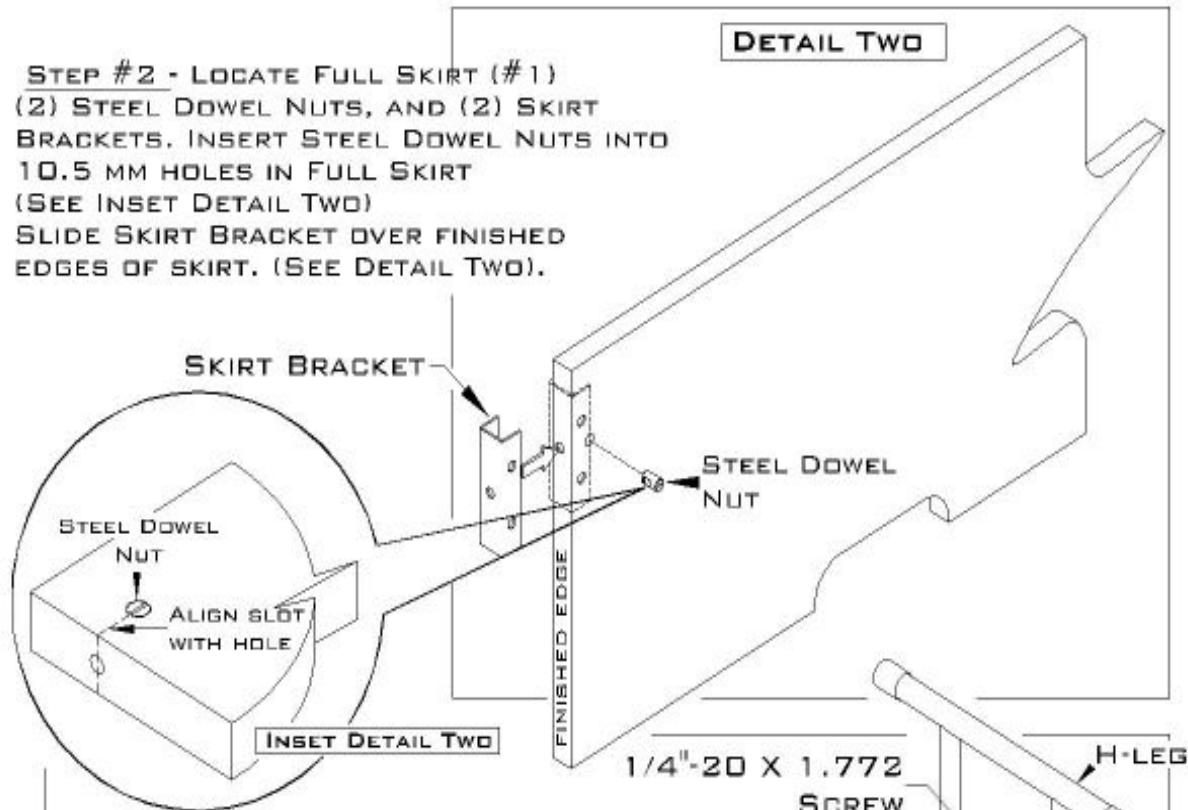

**STEP #3 - LOCATE (2) 1/4"-20 X 1.772."  
 SCREWS. PLACE FULL SKIRT INTO PLACE AND  
 SECURE THROUGH H-LEG CROSS BRACES AT  
 EACH H-LEG USING 1/4"-20 X 1.772"  
 SCREWS. (SEE DETAIL THREE)**

