

# Benee's Storage Unit - Model # KD0100

## HARDWARE / TOOLS

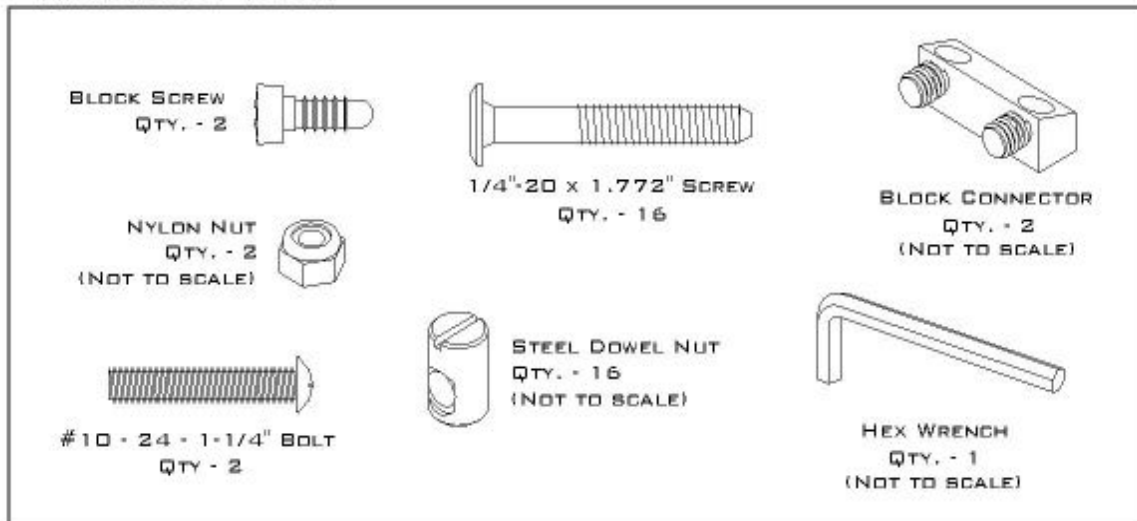

TOOL REQUIRED: PHILLIPS SCREWDRIVER, HEX WRENCH (PROVIDED), WRENCH SET.

NOTE: DO NOT USE A POWER SCREWDRIVER OR A POWER DRILL TO TIGHTEN SCREWS

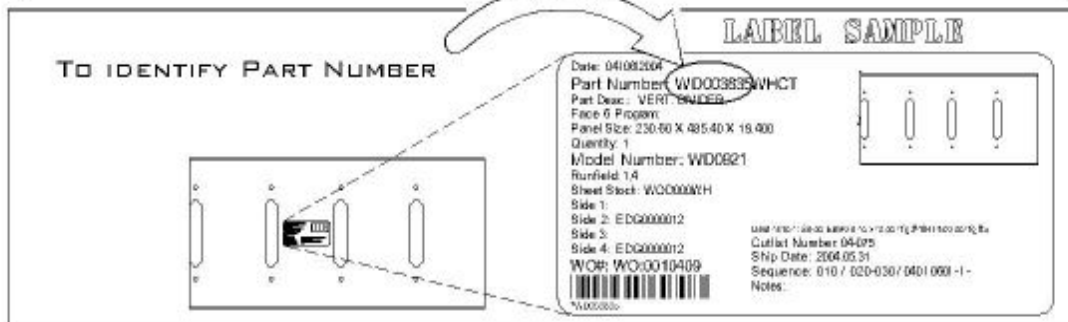

PIECES ENCLOSED: (NOT SHOWN TO SCALE)

Part #	Part Desc.	Qty.
WD02632	Upper & Lower Back	2
WD02624	Middle Back	1
WD03048	Left Side	1
WD03049	Right Side	1

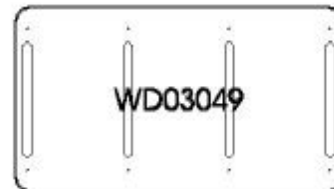
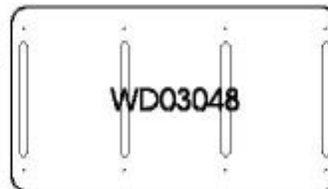

PIECES ENCLOSED LIST CONTINUED TO PAGE 2



PIECES ENCLOSED (CONTUNUED): (NOT SHOWN TO SCALE)



Part #	Part Desc.	Qty.
WD03050	Top Shelf	1
WD03051	Middle Shelf	2
WD03052	Bottom Shelf	1

INSPECT ALL PARTS FOR FREIGHT DAMAGE. IF DAMAGE IS DISCOVERED, AND IT WAS NOT NOTED ON THE BILL OF LADING AT THE TIME OF DELIVERY, PLEASE CALL **benee's** AT 1-800-854-1411.

**STEP #1** - LAYOUT ALL PARTS AND HARDWARE TO INSURE EVERYTHING HAS BEEN INCLUDED AND THAT YOU ARE FAMILIAR WITH THE COMPONENTS.

**STEP #2** - LOCATE RIGHT SIDE (WD03049), (1 TOTAL), TOP SHELF (WD03050) (1 TOTAL), MIDDLE SHELF (WD03051) (2 TOTAL), AND BOTTOM SHELF (WD03052) (1 TOTAL). LAY RIGHT SIDE (WD03049) FLAT ON THE FLOOR AND INSERT TOP SHELF (WD03050), (2) MIDDLE SHELVES (WD03051), AND BOTTOM SHELF (WD03052) INTO SLOTS IN RIGHT SIDE (WD03049). MAKE SURE THAT THE GROOVE IN TOP SHELF (WD03050) IS FACED TOWARD THE BOTTOM SHELF (WD03052) AND THE GROOVE IN BOTTOM SHELF (WD03052) IS FACED TOWARD THE TOP SHELF (WD03050). MAKE SURE THAT THE 10.5 MM HOLES ARE ALWAYS FACED TOWARD THE BOTTOM. (SEE DETAIL ONE)

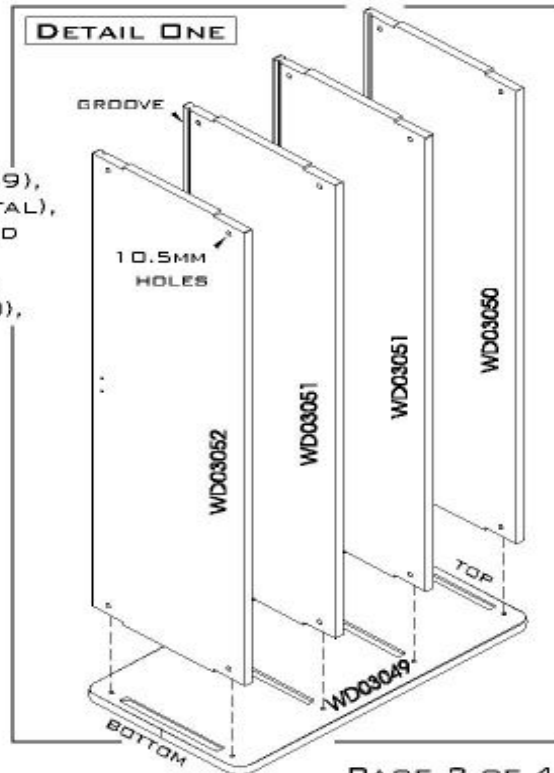

WEB SITE: [WWW.BENEES.COM](http://WWW.BENEES.COM) / EMAIL: [INFO@BENEES.COM](mailto:INFO@BENEES.COM) - PHONE: 1-800-854-1411  
1602 AIRPARK DRIVE - FARMINGTON, MISSOURI 65640 - FAX: (672) 750-2398  
PART# 100K0000 - REVISION DATE: 4/20/06

**STEP #3 - LOCATE UPPER & LOWER BACKS (WDD2632) (2 TOTAL) AND MIDDLE BACK (WDD2624) (1 TOTAL). SLIDE UPPER BACK (WDD2632) INTO GROOVES IN TOP SHELF (WDD3050) AND MIDDLE SHELF (WDD3051) AND MIDDLE BACK (WDD2624) INTO GROOVES IN THE (2) MIDDLE SHELVES (WDD3051), AND BOTTOM BACK (WDD2632) INTO GROOVES IN MIDDLE SHELF (WDD3051) AND BOTTOM SHELF (WDD3052). INSURE THE CENTER HOLES IN TOP BACK (WDD2632) ARE CLOSE TO THE TOP SHELF (WDD3050) AND THAT THE CENTER HOLES IN THE BOTTOM BACK (WDD2632) ARE CLOSE TO THE BOTTOM SHELF (WDD3052) (SEE DETAIL TWO)**

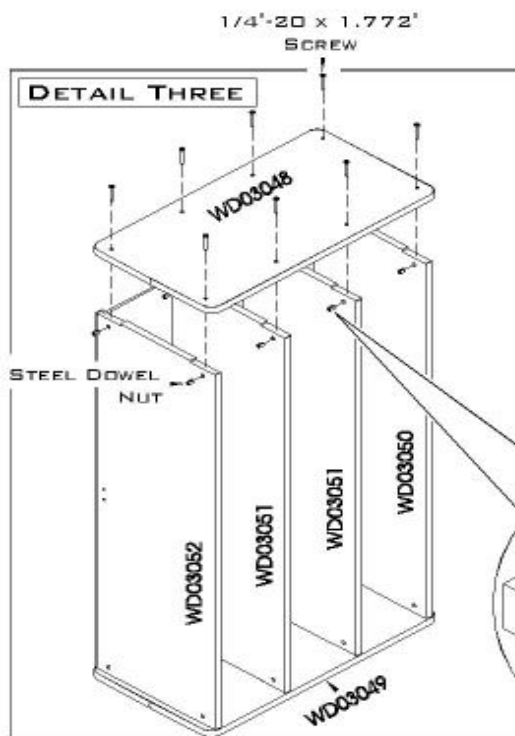
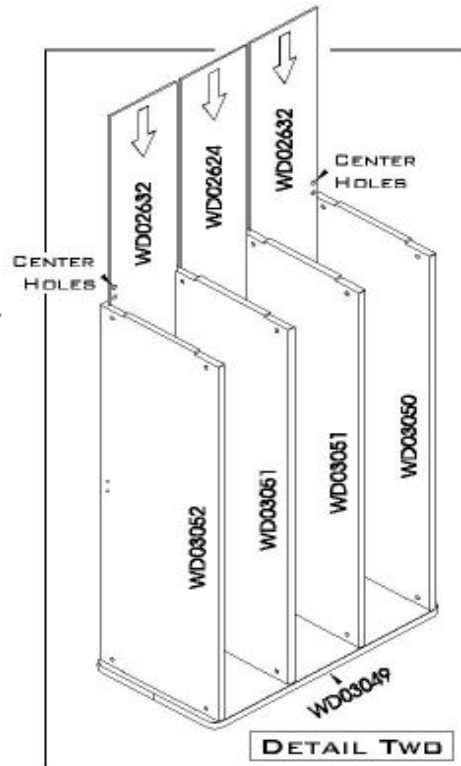

**STEP #4 - INSERT STEEL BARREL NUTS INTO EACH 10.5 MM HOLE IN THE TOP SHELF (WDD3050), MIDDLE SHELF (WDD3051) (2 TOTAL), AND BOTTOM SHELF (WDD3052). LOCATE LEFT SIDE (WDD3048) AND PLACE INTO POSITION. SECURE USING 1/4" - 20 X 1.772 SCREWS (8 TOTAL) USING HEX WRENCH PROVIDED (SEE DETAIL THREE & INSET DETAIL THREE)**

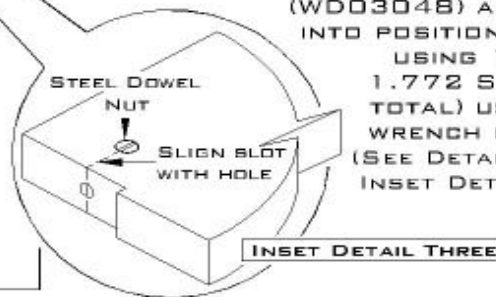

WEB SITE: [WWW.BELCOS.COM](http://WWW.BELCOS.COM) / EMAIL: [INFO@BELCOS.COM](mailto:INFO@BELCOS.COM) - PHONE: 1-800-855-4311  
 1602 AIRPARK DRIVE - FARMINGTON, MASSACHUSETTS 01104 - FAX: 01757-750-2598  
 Part# INKDD000 - Revision Date: 4/2006

**STEP #5** - PLACE UNIT IN AN UPRIGHT POSITION. INSERT STEEL BARREL NUTS INTO EACH 10.5 MM HOLE IN THE TOP SHELF (WDD3050), MIDDLE SHELF (WDD3051) (2 TOTAL), AND BOTTOM SHELF (WDD3052). SECURE LEFT SIDE (WDD3049) USING 1/4"-20 x 1.772" (8 TOTAL) SCREWS USING THE HEX WRENCH PROVIDED. (SEE DETAIL FOUR)

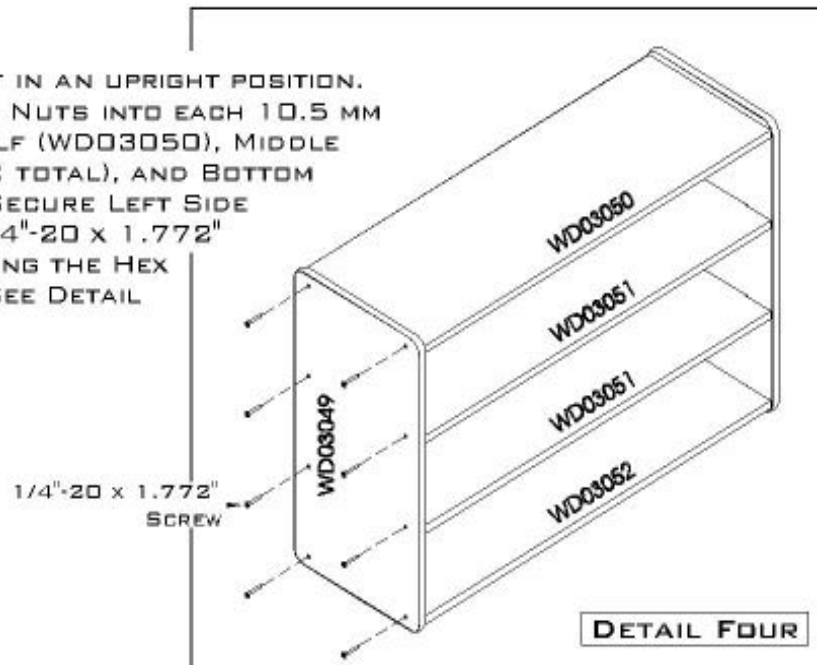

**STEP #6** - PUSH THE TWO PLASTIC DOWELS ON EACH BLOCK CONNECTOR INTO THE TWO CENTER HOLES IN THE UPPER BACK (WDD2632) AND LOWER BACK (WDD2632). INSERT BLOCK CONNECTOR SCREWS (2 TOTAL) INTO BLOCK CONNECTOR AND TIGHTEN TO TOP SHELF (SEE INSET DETAIL FOUR A). ATTACH THE BOTTOM BLOCK CONNECTOR TO THE BOTTOM SHELF (WDD3052) USING #10-24-1-1/4" BOLT (2 TOTAL) (SEE INSET DETAIL FOUR B)

